

Wall / Panel Mounted Sensor Tap - Mains Power Supply

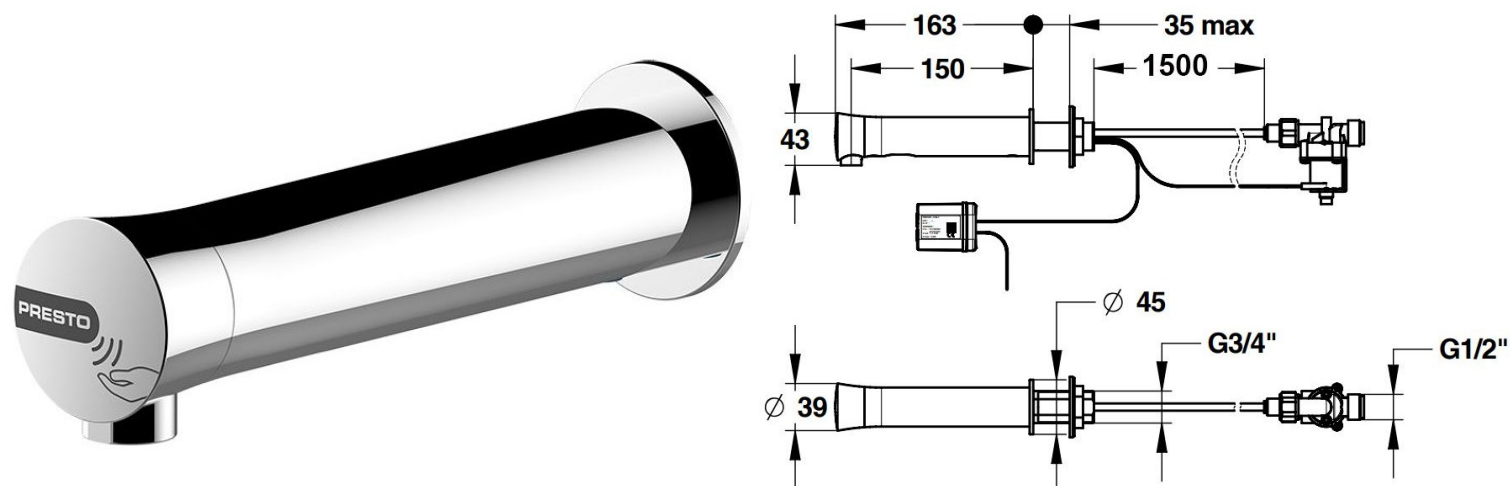

Product Code: WMST-M

These wall mounted sensor operated taps have an infrared sensor with a close detection rate to prevent false activation and a 7 second time flow operation to keep the tap running if hands move out of the sensor range. The mains power supply means no maintenance time changing batteries.

Delivery

From stock typically 1 to 2 working days

Tech Spec

- 7 seconds run time once activated
- The time flow function helps to resolve the problem of the tap turning on and off when the users hands leave the sensor area
- The sensor area is set close to tap to prevent reflections from basins triggering the water flow
- Chrome plated brass body
- Flow rate limited to 1.9 litres per minute
- High quality anti limescale aerator
- Single supply for cold or premixed water
- Mains 240V to 7V transformer in IP65 rated waterproof case
- Anti overflow security run time set to 30 seconds
- Hygiene autoflush function set to run for 30 seconds 24 hours after last use
- Tap hole size 28mm to 30mm
- 1 metre extension leads provided for battery and solenoid connections
- 1.5 metre water inlet tube which can be cut to suit installation
- WRAS approved
- CE marked
- 10 year warranty (excludes battery)

Water Pressure

Min operating pressure required 1 Bar
Max static water pressure 5 Bar

Flow Rates

Pressure (bar)	1	2	3	5
Flow rate (l/min)	1.4	1.6	1.9	1.9

Related Products

[Battery supply model](#)

[TMV3 mixing valve](#) (regulations state these should be fitted close to the tap and ideally one per tap).

Warranty

Warranty is 10 years from supply and is limited to replacement parts or a complete replacement tap. Water filters / Y strainers will need to have been fitted to comply with warranty. Diagnosis and fault finding will need to be undertaken over the phone with the manufacturers before replacement parts or complete taps are supplied. Warranty is strictly limited to parts / replacements and does not cover labour, time or any other consequential charges.

****All pictures shown are for illustration purpose only and may be subject to change without notice. Actual product may vary due to product enhancement.**

All dimensions shown are for guidance only and may be subject to change or alteration without notice. All items manufactured or purchased separately from a third party to fit our products should be checked against the actual dimensions of the physical product before purchase. We will not be liable for third party costs and consequential loss associated with the items not fitting third party components.**